

Fall Protection Block

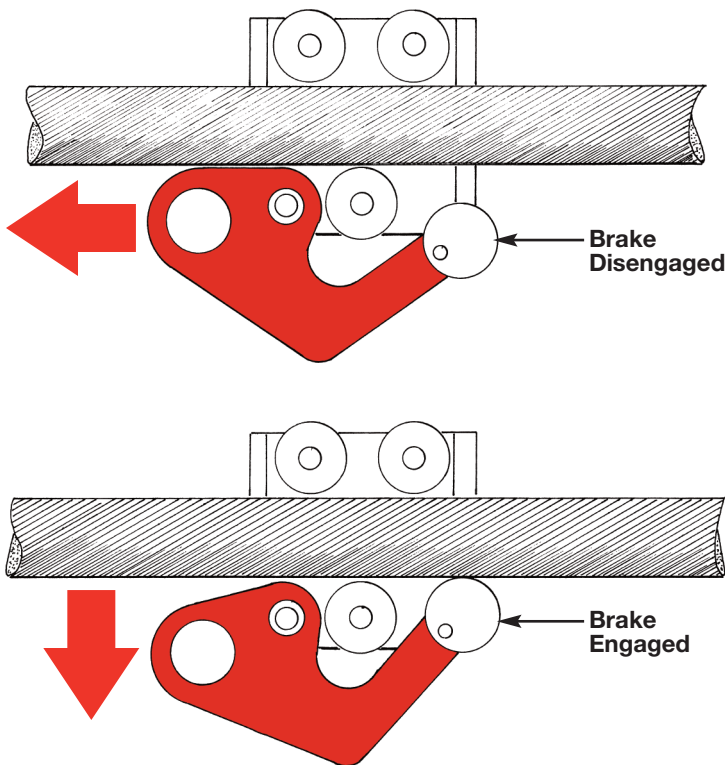

The **Fall Protection Block** is unpinned and opens up to be put on and taken off of the conductor. The side is secured with a welded hinge pin and push-button locking pin. UHMW rollers, side guides and brake pad prevent the block from causing damage to the conductor.

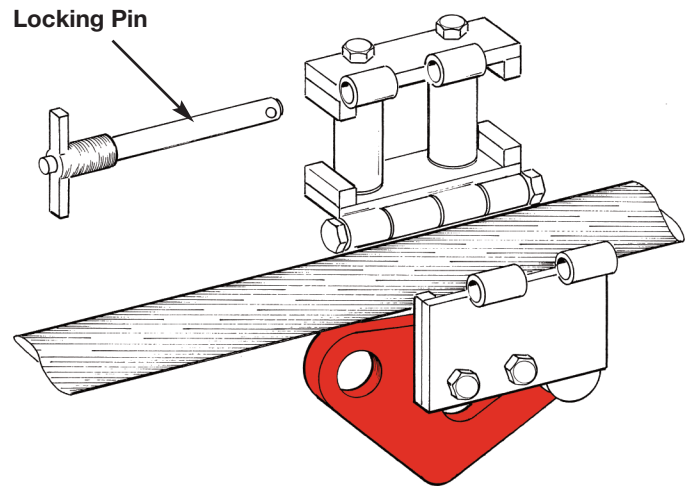

The Lineman's shock absorbing fall protection lanyard is hooked to the ring on the front of the block. The block is pulled down the conductor by the lanyard. In the event the Lineman falls, the shock-absorbing lanyard pulls down on the ring on the front of the block and the brake is applied to prevent the block from running on the wire.

Specifications

Overall Width	4½"
Overall Length	6½"
Overall Height	7"
Frame Width	3"
Frame Length	4¼"
Frame Height	4"
Weight	4 lbs.
Push-button Locking Pin	½" dia.
Roller	1¼" dia. UHMW
Side Guides	⅜" Sq. UHMW

Must be used with 1,800 lb. shock-absorbing lanyard.